



# **ZEISS SPECTRUM plus**

## Specifications

Version: 2021-11



Seeing beyond

## System description

Type according to ISO 10360-1:2000	Bridge-type CMM with a moveable bridge				
Operating mode	Motorized / CNC				
Sensor mounts	Fixed installation				
Software	ZEISS CALYPSO				
			<b>5/5/6</b>	<b>7/7/6 and 7/10/6</b>	<b>10/12/6 and 10/16/6</b>
Travel speed <sup>4)</sup>	Motorized	Axes	0 to 70 mm/s	0 to 70 mm/s	0 to 70 mm/s
	CNC	Vector	max. 346 mm/s	max. 346 mm/s	max. 346 mm/s
Acceleration <sup>5)</sup>		Vector	max. 866 mm/s <sup>2</sup>	max. 866 mm/s <sup>2</sup>	max. 866 mm/s <sup>2</sup>

## ZEISS SPECTRUM plus sensors and accuracy

The functionality of the device and its specifications are only achievable when using original accessories by ZEISS. The specified parameters are observed in the application of the internal test instructions for acceptance testing and in the use of the released standards in accordance with the ISO 10360 series.

### ZEISS VAST XT gold <sup>1)</sup>



Active scanning and multipoint sensor. Scanning measuring rate up to 500 points/s.  
Variable measuring force (50-1000 mN) for data acquisition.  
ZEISS VAST XT gold: stylus: max. length = 500 mm, max. weight = 500 g incl. stylus adapter,  
min. stylus tip diameter = 0.5 mm.

			<b>5/5/6</b>	<b>7/7/6 and 7/10/6</b>	<b>10/12/6 and 10/16/6</b>
<b>Length measurement error <sup>2)</sup></b> MPE complies with ISO 10360-2:2009	E0 / E150	in µm	1.8 + L/300	1.8 + L/300	1.9 + L/300
<b>Repeatability range of E0</b> MPL complies with ISO 10360-2:2009	R0	in µm	1.7	1.7	1.8
<b>Scanning error</b> MPE complies with ISO 10360-4:2000	THP	in µm	2.5	2.5	3.0
Required measuring time MPT	τ	in s	40	40	40
<b>Form measurement error <sup>3)</sup></b> MPE for roundness complies with ISO 12181 (VDI/VDE 2617 sheet 2.2)	RONt (MZCI)	in µm	1.8	1.8	1.9
<b>Single stylus form probing error</b> MPE complies with ISO 10360-5:2010	PFTU	in µm	1.8	1.8	1.9

1) Acceptance test for a stylus length of 60 mm and a tip diameter of 8 mm. Also valid for other styli. Dia. 3 x 33 mm, dia. 5 x 50 mm, dia. 8 x 114 mm and dia. 12 x 92 mm were tested.

2) Measuring length L in mm.

3) Roundness in scanning operations on a 50 mm ring gauge with v 5 mm/sec, filter 50 UPR.

4) Only ZEISS SPECTRUM plus with ZEISS VAST XT gold allows a higher travel speed (CNC vector max. 469 mm/s) for all sizes.

5) Only ZEISS SPECTRUM plus with ZEISS VAST XT gold allows a higher acceleration (vector max. 1855 mm/s<sup>2</sup>) for all sizes.

## ZEISS SPECTRUM plus Sensors and accuracy

The functionality of the device and its specifications are only achievable when using original accessories by ZEISS. The specified parameters are observed in the application of the internal test instructions for acceptance testing and in the use of the released standards in accordance with the ISO 10360 series.

### ZEISS RDS-C



Dynamic ZEISS RDS-C articulating unit for contact sensors.

Lateral swivel axis offers more benefits than articulating systems with front-to-back and lateral tilt axis; front-to-back and lateral tilt range of  $\pm 180^\circ$ , large measuring range, rotation increments of  $2.5^\circ$ , CAA correction to automatically qualify all potential 20.736 angular positions.

### ZEISS VAST XXT

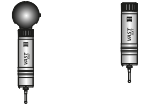

Measuring contact sensor direct or attached to the ZEISS RDS-C articulating probe holder.

Stylus length with TL3 module = 30-150 mm; maximum sensor extension = 100 mm; maximum stylus weight = 15 g; minimum stylus tip diameter = 0.3 mm.

			5/5/6	7/7/6 and 7/10/6	10/12/6 and 10/16/6
<b>Length measurement error</b> <sup>1) 2) 3)</sup> MPE complies with ISO 10360-2:2009	E0	in $\mu\text{m}$ ZEISS VAST XXT	1.8 + L/300	1.8 + L/300	1.9 + L/300
<b>Repeatability range of E0</b> MPL complies with ISO 10360-2:2009	R0	in $\mu\text{m}$	1.8	1.8	1.9
<b>Scanning tolerance</b> MPE complies with ISO 10360-4:2000	THP	in $\mu\text{m}$	3.2	3.5	3.5
Required measuring time MPT	$\tau$	in s	50	50	50
<b>Form measurement error</b> <sup>4)</sup> MPE for roundness complies with ISO 12181 (VDI/VDE 2617 sheet 2.2)	RONT (MZCI)	in $\mu\text{m}$	1.8	1.9	1.9
<b>Single stylus form error</b> MPE complies with ISO 10360-5:2010	PFTU	in $\mu\text{m}$	1.8	2.0	2.0

### Sensor overview SPECTRUM plus

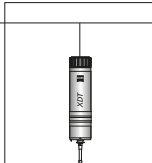
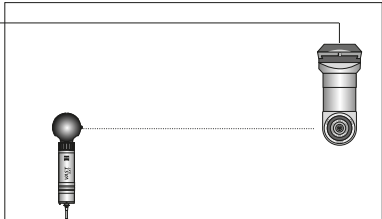
	active	direct	RDS
			
	VAST XT gold	VAST XXT	VAST XXT RDS-C
<b>Multipoint</b>	■	■	■
<b>Passive scanning</b>		■	■
<b>Active scanning</b>	■		
<b>Max. stylus length</b> <sup>5)</sup>	500 mm	150 mm	150 mm
<b>Max. stylus weight</b> <sup>5)</sup>	500 g	15 g	15 g

- 1) Acceptance test for ZEISS VAST XXT with stylus length of 50 mm and sphere diameter of 3 mm.
- 2) Measuring length L in mm.
- 3) In compliance with the specified ambient conditions.
- 4) Roundness in scanning operations on a 50 mm ring gauge with v 5 mm/sec, filter 50 UPR.
- 5) Depending on the application, limiting the parameters for a stylus configuration may be useful.

ZEISS SPECTRUM plus Sizes	Dimensions in mm													Weight in kg	
	Measuring range			Overall CMM dimensions			Working range (Max. workpiece size)				Table height	Assembly space	Transport height <sup>2)</sup>	CMM	Max. workpiece
	X axis	Y axis	Z axis	Width	Length	Height	Width	Length	Height	Height	Height	Height	Height		
	G104	G105	G106	B6	B5	B7	B17	B16	B18	h	B23	c1	T		
5/5/6	500	500	600	1219	1283	2640	715	830	620 <sup>1)</sup>	845	700	≥200	2050	910	400
7/7/6	700	700	600	1419	1483	2640	915	1030	620 <sup>1)</sup>	845	700	≥200	2050	1180	560
7/10/6	700	1000	600	1419	1783	2640	915	1335	620 <sup>1)</sup>	845	700	≥200	2050	1410	730
10/12/6	1000	1200	600	1720	1983	2640	1220	1535	620 <sup>1)</sup>	845	700	≥200	2050	2200	1150
10/16/6	1000	1600	600	1720	2383	2640	1220	1935	620 <sup>1)</sup>	845	700	≥200	2050	2700	1500

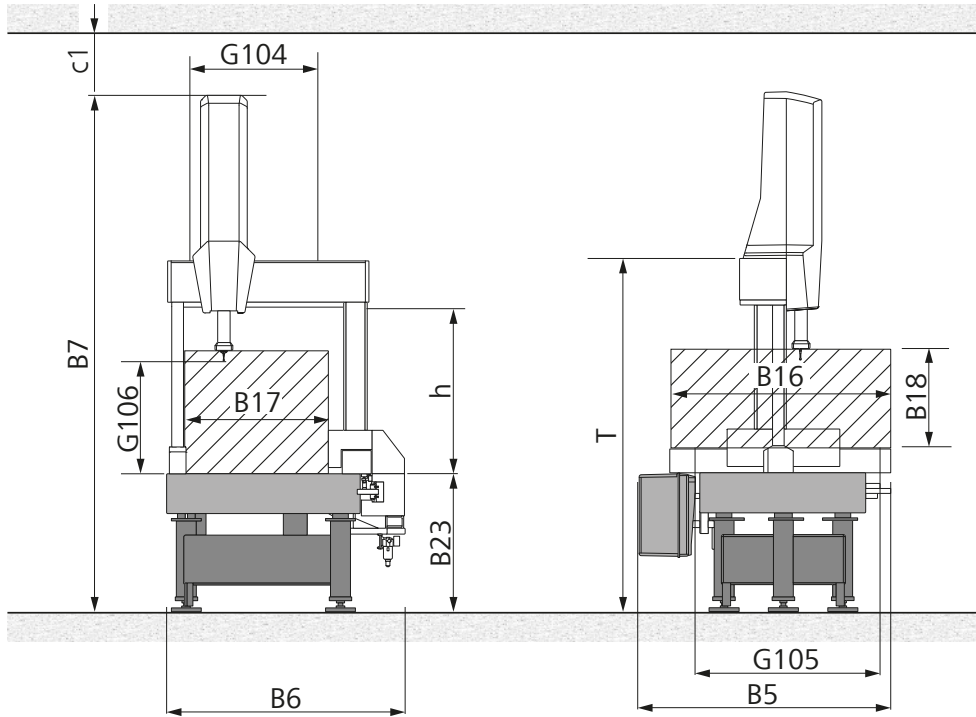

ZEISS VAST XTgold

ZEISS VAST XXX direct

ZEISS RDS-C

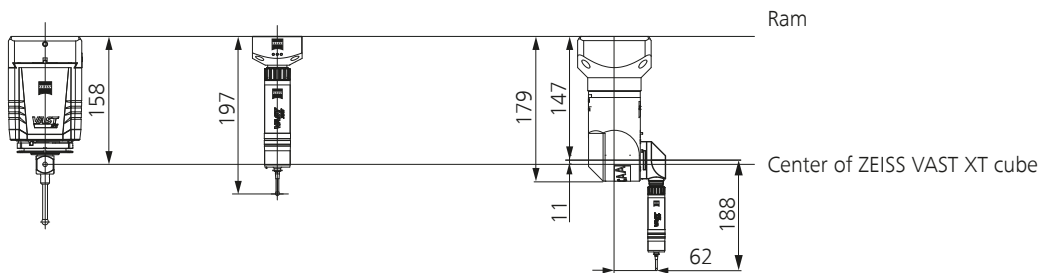

Note: The given dimensions and weights are approximate values. Subject to change. Actual appearance of specific sizes may vary from illustration. Measuring range in Z (G106) and working area height (B18) may vary depending upon probe configuration. Dimensioning based on DIN 4000-167:2009.

- 1) Valid for ZEISS VAST XXX only (to bottom edge of the ZEISS XXX sensor). Working range height (B18) is less for other sensor configurations.
- 2) Transport height of the secured machine group without pallet or Z tower. When transporting without foundation, deduct 600 mm from the transport height value.

## Technical features

Length measuring system	Reflected light length measuring system, photoelectric 0.2 µm resolution	
Controller	Type	ZEISS C99L
	Cooling system:	Fan
Accessories (optional)	Multi-sensor Rack (MSR)	for storage of stylus systems

## Ambient requirements <sup>1)</sup>

Relative humidity	40 - 60% (without condensation)	
Measuring reference temperature from	18°C to 22° <sup>2)</sup>	
	Per day	1.5 K/d
	Per hour	1.0 K/h
	Spatial	1.0 K/m

## Requirements for operational readiness

Relative humidity	40 - 60% (without condensation)
Ambient temperature	+17°C to +35°C

## Connection data

Power rating <sup>3)</sup>	1/N/PE 100-240 V 50-60 Hz, Power consumption: max. 600VA Amount of heat generated: max. 2160 kJ/h
Compressed air supply	Supply pressure min. 6 bar, max. 8 bar, pre-cleaned. Max. consumption: 120Nl/min.  Air quality complies with ISO 8573 Part 1: Class 4, i.e. Paragraph. 6.1: max. particle size 15 µm, max. dirt particle concentration 8 mg/m <sup>3</sup> Paragraph 6.2: max. compressed air dew point +3°C Paragraph 6.3: max. oil concentration of 5 mg/m <sup>3</sup> If the air supply does not comply with the above requirements, an additional air filter unit and, if necessary, a membrane dryer must be inserted in the compressed air line.

## Approvals

Directives	ZEISS SPECTRUM plus complies with EC machine directive 2006/42/EC, EMC directive 2014/30/EU and RoHS directive 2011/65/EU.  
Disposal	ZEISS products and packaging returned to us are disposed of in accordance with applicable legal provisions.

## Certifications / accreditation

Quality management system	ISO 9001:2015; VDA 6, Parts 4, 3. Version 2017
Environmental management system	ISO 14001:2015
Occupational health & safety management systems	BS OHSAS 18001:2007
Accredited	ISO / IEC 17025:2005

1) To ensure specified accuracies.

2) At a measuring lab temperature that has remained constant for 48 hours.

3) Only ZEISS SPECTRUM plus with ZEISS VAST XT gold has a power consumption of max. 800VA and an amount of heat generated of max. 2880 kJ/h.

**Carl Zeiss**

**Industrielle Messtechnik GmbH**

73446 Oberkochen, Germany

Sales: +49 (0) 7364/ 20-6336

Service: +49 (0) 7364/ 20-6337

Fax: +49 (0) 7364/ 20-3870

Email: [info.metrology.de@zeiss.com](mailto:info.metrology.de@zeiss.com)

Internet: [www.zeiss.com/imt](http://www.zeiss.com/imt)

**Carl Zeiss**

**Industrial Metrology**

6250 Sycamore Lane North

Maple Grove, MN 55369/USA

Phone: +1 (763) 744-2400

Fax: +1 (763) 533-0219

Email: [info.metrology.us@zeiss.com](mailto:info.metrology.us@zeiss.com)

Internet: [www.zeiss.com/metrology](http://www.zeiss.com/metrology)